

**Specification  
for  
Lithium-ion Rechargeable Cell**

**锂离子电池规格书**

**Cell Type : ESS 4LH3L7 280A**

**电芯型号 : ESS 4LH3L7 280A**

<b>Document No.</b>		<b>Version Change Date</b>	2023-04-30
<b>Version</b>	A1	<b>Pages</b>	16
<b>Customer</b>	<b>Approved</b>	<b>Checked</b>	<b>Designed</b>
	Max Xu	Jerry Song	Jin Wang

## 规格书修订记录

日期	内容	版本
2022-1-20	新发行	A0
2023-4-30	电芯重量变更	A1

## Contents 目录

Contents 目录.....	2
1. Scope 适用范围 .....	3
2. Normative references 规范性引用文件 .....	3
3. Definition 定义.....	3
3.1 Room Temperature 室温.....	3
3.2 Rated Capacity 额定容量 .....	3
3.3 Charge & Discharge Rate 充放电倍率.....	3
3.4 Cycle life 循环寿命 .....	3
3.5 Open Circuit Voltage (OCV) 开路电压 .....	4
3.6 Operating Voltage 工作电压.....	4
3.7 Standard Charge Method 标准充电.....	4
3.8 Standard Discharge Method 标准放电.....	4
3.9 Rapid Discharge Method 快速放电.....	4
3.10 Restore Capacity 可恢复容量 .....	4
3.11 Discharge Retention 荷电保持能力 .....	4
3.12 Capacity recovery capability 容量恢复能力.....	5
3.13 State of Charge (SOC) 荷电状态.....	5
3.14 Units of Measurement 测量单位 .....	5
3.15 Welding parameters of post terminal and busbar 极柱与 Busbar 焊接参数 .....	6
4. Cell Size 电池型号及尺寸 .....	6
4.1 Description and model 电池说明及型号 .....	6
4.2 Cell size 电池尺寸 .....	6
5. Product Performance 产品性能.....	7
5.1 Technical Parameters 技术参数 .....	7
5.2 Charging Model 充电模式 .....	8
5.3 C-Rate Other charge Condition (C-Rate) 其他充电条件(模式).....	8
5.4 C-Rate Other discharge Condition (C-Rate) 其他放电条件(模式) .....	8
5.5 Discharging Model 放电模式.....	8
5.6 OCV 开路电压.....	10
5.7 Safety Characteristics 安全性能.....	10
5.8 Storage Performance 储存性能.....	11
6. Precautions for Transportation 运输注意事项 .....	12
7. Warranty 质量保证.....	12
8. Storage and Shipment Requirement 存储及运输要求.....	13
9. Warning and Cautions in Handling the Lithium-ion Cell 电池使用时警告事项及注意事项 .....	13
10. Emergency Treatment 紧急情况处理 .....	15
11. The Restriction of the Use of Hazardous Substances 有害物质控制要求.....	15

## 1. Scope 适用范围

This specification describes the type, size, performance, technical characteristics, warning and caution of the lithium-ion rechargeable cell supplied by Envision AESC.

本标准描述了远景 AESC 生产的方形锂离子电池的外型尺寸、特性、技术要求及注意事项。

## 2. Normative references 规范性引用文件

The following standards are cited in the preparation of this specification. For undated references, the latest version is applicable.

本规格书的编写引用了以下标准，凡是不注日期的引用文件，其最新版本适用于本标准。

GB/T 36276-2018 Lithium-ion batteries for power energy storage

IEC62619

UL1973

UL9540A

UN38.3

## 3. Definition 定义

### 3.1 Room Temperature 室温:25±2°C

### 3.2 Rated Capacity 额定容量:

Rated capacity:  $Cap = 280Ah$ . Under 25±2°C, it means the capacity value of being measured by standard charge and discharge, which is signed  $Cap$ , the unit is Ah.

额定容量 280Ah，指在 25±2°C 环境下，以标准充放电模式测出的容量，以  $Cap$  表示，单位为安培时 (Ah)。

### 3.3 Charge & Discharge Rate 充放电倍率

The ratio of charging or discharging power to the energy of batteries measured repeatedly by BMS. For example, when the battery energy is 896Wh and the charging or discharging power is 448W, the charging or discharging rate is 0.5P.

充电功率与电池管理系统多次测量的电池的能量值的比率。例如：电池能量为 896Wh，充电功率或者放电功率为 448W 时，则充电倍率或者放电倍率为 0.5P。

### 3.4 Cycle life 循环寿命

With the repeated charging and discharging, the battery's capacity will gradually decline. Usually the rated capacity of the battery is a standard, the number of charge-discharge cycles a battery can go through before it reaches 80% of its rated capacity called cycle life.

二次电池在反复充放电的使用下，电池的容量会逐渐下降，通常以该电池的额定容量作为标准，电

池容量降到其 80%的充放电次数，称为循环寿命。

### 3.5 Open Circuit Voltage (OCV) 开路电压

Open-circuit voltage is the difference of electrical potential between two tabs of a device when disconnected from any circuit.

开路电压是指外电路没有电流流过时电池正负极耳之间的电位差。

### 3.6 Operating Voltage 工作电压

Operating voltage, also known as the discharge voltage or load voltage, is defined as the potential difference between the battery terminals when the current transmits through the external circuit. Working voltage is always lower than the open circuit voltage, because when the current transmits through the battery internal, the polarization resistance and ohmic resistance must be overcome.

工作电压又称放电电压或负荷电压，是指有电流通过外电路时，电池两极间的电位差。工作电压总是低于开路电压，因为电流流过电池内部时，必须克服极化电阻和欧姆内阻所造成的阻力。

### 3.7 Standard Charge Method 标准充电

Under  $25\pm 2^{\circ}\text{C}$ , it can be charged to 3.65V with constant power of 1P.

在  $25\pm 2^{\circ}\text{C}$  环境下，以 0.5P 的恒功率充电至单体电池电压 3.65V，停止充电。

### 3.8 Standard Discharge Method 标准放电

At  $25\pm 2^{\circ}\text{C}$ , it can be discharged to the voltage of 2.5 V with constant power of 1P.

在  $25\pm 2^{\circ}\text{C}$  环境下，以 0.5P 的恒功率放电至单体电池的终止电压 2.5V。

### 3.9 Rapid Discharge Method 快速放电

At  $25\pm 2^{\circ}\text{C}$ , it can be discharged to the voltage of 2.5 V with constant current of 1P.

指在  $25\pm 2^{\circ}\text{C}$  环境下，以 1P 的恒功率放电至单体电池的终止电压 2.5 V。

### 3.10 Restore Capacity 可恢复容量

After storage, the capacity tested according to the standard charge and discharge conditions listed in section 3.7 and 3.8, the maximum of 3 measured discharge values was selected as restore capacity.

电池储存后，按照本规格书第 3.7 和 3.8 条所列的标准充放电条件所测得的容量，取值分别按照本规格书第 3.7 和 3.8 条给出的充放电标准，分选取 3 次测量的最大值。

### 3.11 Discharge Retention 荷电保持能力

The percentage of the discharge capacity by the standard discharge method and rated capacity after the battery which has been standard charged to 100%SOC stored in a certain temperature and time condition.

标准充电后的电池在一定温度下，储存一定时间后，以标准放电方法所获得的容量与额定容量之比

的百分数。

### 3.12 Capacity recovery capability 容量恢复能力

The percentage of the discharge capacity and rated capacity with recharging after the battery stored in a certain temperature and time.

电池在一定温度下，储存一定时间后再行充电，其后放电容量与额定容量之比的百分数。

### 3.13 State of Charge (SOC) 荷电状态

The percentage of remaining energy. Only with estimating the battery SOC accurately can improve the utilization efficiency of the battery, and ensure the battery life and safety.

电池剩余电量百分比，电池一个重要的参数，只有准确估算电池 SOC 才能有效提高电池利用效率、保证电池的使用寿命和安全。

### 3.14 Units of Measurement 测量单位

① “V” (Volt) ,Unit of voltage

“V” (Volt) 伏特，电压单位

② “A” (Ampere) ,Unit of current

“A” (Ampere) 安培，电流单位

③ “Ah” (Ampere-Hour) ,Unit of electric charge

“Ah” (Ampere-Hour) 安培-小时，电荷单位

④ “Wh” (Watt-Hour) ,Unit of energy

“Wh” (Watt-Hour) 瓦特-小时，能量单位

⑤ “mΩ” (MilliOhm) ,Unit of resistance

“mΩ” (MilliOhm) 毫欧姆，电阻单位

⑥ “°C” (degree Celsius) ,Unit of temperature

“°C” (degree Celsius) 摄氏度，温度单位

⑦ “mm” (millimeter) ,Unit of length

“mm” (millimeter) 毫米，长度单位

⑧ “s” (second) ,Unit of time

“s” (second) 秒，时间单位

⑨ “Hz” (Hertz) ,Unit of frequency

“Hz” (Hertz) 赫兹，频率单位

### 3.15 Welding parameters of post terminal and busbar 极柱与 Busbar 焊接参数

No. 序号	Item 项目	Standard 标准
1	Welding area 焊印面积	$\geq 34\text{mm}^2$
2	Depth of fusion 熔深	0.5~1.2mm
3	Width of fusion 熔宽	$\geq 1\text{mm}$
4	Drawing force 拉拔力	$\geq 600\text{N}$
5	Temperature of post terminal plastic parts 极柱塑胶件温度	200℃持续<30s
6	Pressure on post terminal 极柱承受压力	$\leq 500\text{N}$

## 4. Cell Size 电池型号及尺寸

### 4.1 Description and model 电池说明及型号

Description: Prismatic Li-ion rechargeable cell

Model: 4LH3L7 3.2V 280A

4LH3L7 3.2V 280A 型号方形锂离子二次电池

### 4.2 Cell size 电池尺寸

The size diagram of the cell is shown in the following figure (Unit: mm). (Remark: The bottom of cell is hollowed out, and there is no insulation patch)

电池尺寸图如下图所示（单位：mm）。（备注：电芯底部镂空，无绝缘贴片）

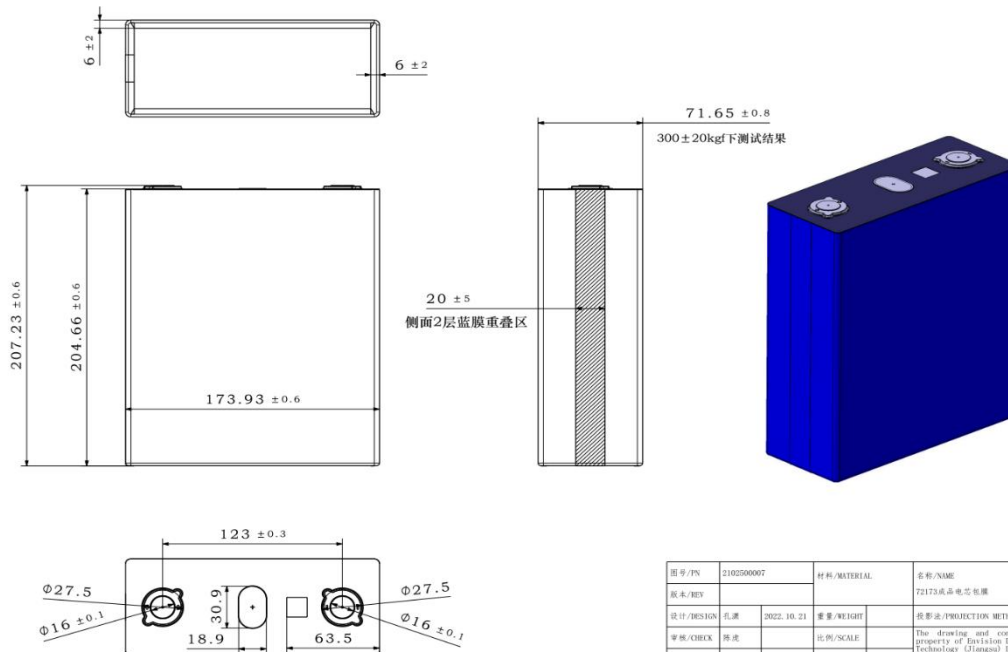

图号/PN	2102500007	材料/MATERIAL	名称/NAME
版本/REV			72173成品电芯包装
设计/DESIGN	孔涛	2022.10.21	数量/WEIGHT
审核/CHECK	陈波		比例/SCALE
工艺/TECH			图框/FORMAT

The drawing and content is property of Envision Dynamics Technology (Shenzhen) LTD. It may not be used, copied or published without written permission of the owner.

## 5. Product Performance 产品性能

Fresh cell, tested at 25±2°C, standard charge and discharge unless otherwise specified

电池特性（除非有特殊说明，否则所有测试要求为：温度在 25±2°C 条件下，样品为新电池，充放电制度为标准充电和标准放电）

### 5.1 Technical Parameters 技术参数

ITEM 项目	SPECIFICATION 特性
Cell Type 电芯类型	LFP Cell 磷酸铁锂电芯
Nominal Capacity 额定容量	280Ah
Nominal voltage 额定电压	3.20V
Charge ending voltage 充电终止电压	3.65V
Discharge ending voltage 放电终止电压	2.5V (0<T≤60°C) 2.0V (-30°C≤T≤0°C)
Nominal energy 额定能量	896Wh
Standard charge/discharge power 标准充放电功率	0.5P
Max. continuous charge/discharge power 最大持续充放电功率	1P
Charge temperature range 充电温度窗口	0~60°C
Discharge temperature range 放电温度窗口	-30~60°C
Storage temperature 存储温度	-30~60°C
Internal resistance 内阻	≤ 0.4mΩ (AC Impedance, 1000 Hz)
Cycle life 循环	≥6000cycles (25±2°C 初始夹紧力 300Kgf, 标准充放电测试 25±2°C, cycle test by the standard charge and discharge method under 300±20Kgf preload)
Recommended SOC window 推荐 SOC 使用窗口	SOC: 0%~100%
Cell size 电芯尺寸	Thickness: 71.65±0.80 mm 厚度: 71.65±0.80mm (含蓝膜) Width: 173.93±0.60mm 宽度: 173.93±0.60mm (含蓝膜) Height: 207.23±0.60mm 高度: 207.23±0.60mm (含极柱、底盖)
Weight 重量	5.300±0.150kg

## 5.2 Charging Model 充电模式

NO. 序号	Parameter 参数	Values 规格	Remarks 备注
5.2.1	Standard Charging Model 标准充电模式	the standard charge model according to the conditions listed in section 3.7 同3.7测试标准	
5.2.2	Standard Charging Temperature 标准充电温度	25±2℃	Cell Temperature 电池温度
5.2.3	Absolute Charging Temperature 绝对充电温度	0~60℃	No matter what the charging model is, once the temperature of the cell is above the absolute charging temperature, charging should be stopped. 无论电池处在何种充电模式，一旦发现电池温度超过绝对充电温度范围，即停止充电
5.2.4	Absolute Charging Voltage 绝对充电电压	Maximum 3.65V 最大3.65V	No matter what the charging model is, including pulse charging, once the voltage of the cell is above the absolute charging voltage, charging should be stopped. 无论电池处在何种充电模式包括脉冲充电状态，一旦发现电池电压超过绝对充电电压范围，即停止充电

## 5.3 C-Rate Other charge Condition (C-Rate) 其他充电条件(模式)

Cell temperature range 电池温度范围	<0℃	0-15℃	15-20℃	20-45℃	45-60℃	>60℃
Maximum charging power allowed允许最大充电功率	Not allowed 不允许	0.1P	0.5P	1P	0.5P	Not allowed 不允许

## 5.4 C-Rate Other discharge Condition (C-Rate) 其他放电条件(模式)

Cell temperature range 电池温度范围	<-30℃	-30-0℃	0-45℃	45-60℃	>60℃
Maximum charging power allowed允许最大充电功率	Not allowed 不允许	0.5P	1P	0.5P	Not allowed 不允许

## 5.5 Discharging Model 放电模式

### ① Test Conditions 测试条件

Unless otherwise specified, all the experiments should be carried out under ambient temperature: 25±2℃, relative humidity: 25%~85% and atmospheric pressure: 86KPa~106KPa.

除另有规定外，试验应在温度为：25±2℃，相对湿度为：25%~85%，大气压力为：86KPa~106KPa 的环境中进行。

### ② Requirements of Measuring Instruments and Facilities 测量仪表与设备要求

All of the measuring instruments and facilities (include the equipments which monitor the test parameters) should be verified and calibrated qualified by relevant Chinese Calibration Regulation or certain standards

within the valid date. All the test instruments and equipments should have adequate precision and stability and the precision should be an order higher than the tested indicators or the tolerance should be less than one third of the tested parameters.

检验测试的所有仪表、设备（包括监控和监视试验参数的试验设备和仪器）应按国家有关计量检定规程或有关标准经检定或计量合格，并在有效期内。所有测试仪表、设备应具有足够的精度和稳定度，其精度应高于被测指标精度一个数量级或误差小于被测参数允许误差的三分之一。

NO. 序号	Items 项目	Technical Requirements 技术要求	Test Methods 测试方法及步骤
1	Appearance 外观	No damage, leakage, oil contamination. Legibly marked. 电池应无破损、漏液、油污等缺陷，标识清楚。	Visual Inspection 目测法
2	Discharging performance under room temperature 室温放电性能	Discharging Capacity/Nominal Capacity×100%: 放电容量/额定容量×100%: Discharged at 0.5P ≥100% 0.5P 放电时≥100%	It's the capacity (in Ah) when batteries are discharged to 2.5V with 0.5P (448W) at 25±2°C. 室温下，以 0.5P (448W) 进行放电至下限电压 2.5V，计算放量（以 Ah 计）。
3	Discharging characteristics under high and low temperatures 高低温放电性能	Discharging Capacity/Nominal Capacity×100%: 放电容量/额定容量×100%: a) Discharged at 60°C ≥98% 60°C时≥98% b) Discharged at -20°C ≥70% -20°C时≥70%	High-temperature discharge capacity: 高温放电容量: a) Standard charge 电池标准充电; b) Be set aside for 5h at 60±2°C; 在60±2°C条件下搁置5h; c) Discharging the battery to 2.5V with 1P at 60±2°C, calculate the capacity. 在60±2°C条件下以1P放电至终止电压2.5V, 计算放电容量（以Ah计）。 Low-temperature discharge capacity test: 低温放电容量试验按如下步骤进行: a) Standard charge 电池标准充电; b) Be set aside for 24h at -20±2°C; 在-20±2°C条件下搁置24h; c) Discharging the battery to 2.0V with 1P at -20±2°C, calculate the capacity 在-20±2°C条件下以1P放电至终止电压2.0V, 计算放电容量（以Ah计）。
4	Discharge retention and capacity recoverable capability under room temperature 常温荷电保持	Discharge retention ≥97% 荷电保持率≥97% Capacity recovery ≥98% 容量恢复率≥98%	a) Standard charge 电池标准充电; b) Stored for 28 days at 25±2°C; 在25±2°C条件下储存28天; c) Under room temperature, discharge it at 1P to cut-off voltage and calculate retention capacity (in Ah). 室温下，以1P放电至终止电压，计算荷电保持容量（以Ah计）;

	与容量恢复能力		<p>d) Then standard charged again; 电池再进行标准充电;</p> <p>e) Under room temperature, discharge it at 1P to cut-off voltage and calculate recovery capacity (in Ah). 室温下, 以1P 放电至终止电压, 计算恢复容量 (以Ah计)。</p>
5	循环寿命 Cycle Life	<p>≥6000次 ≥6000 cycles</p>	<p>a) At room temperature, charged to 3.65V at a constant power of 0.5P (448W) 室温下, 以0.5P恒功率持续充电至单体电池电压3.65V</p> <p>b) Discharged at 0.5P to the cut-off voltage at room temperature; 室温下, 以0.5P恒功率放电至终止电压;</p> <p>c) Repeating steps of a) ~ b), until the discharge capacity reached the 80% of rated capacity, the number of cycles completed was defined as the battery cycle life. 重复a) ~b), 至容量衰减为额定容量的80%止, 所完成的循环次数定义为该电池的循环寿命。</p>

### 5.6 OCV 开路电压

SOC	0%	10%	20%	30%	40%	50%	60%	70%	80%	90%	100%
OCV	2.767	3.215	3.267	3.294	3.298	3.300	3.330	3.336	3.337	3.337	3.483

### 5.7 Safety Characteristics 安全性能

序号 NO.	项目 Items	技术要求 Technical Requirements	测试方法及步骤 Test Methods & Steps
1	过充电 Overcharge Test	不爆炸、不起火 No explosion. No fire.	<p>a) Standard charge 电池标准充电;</p> <p>b) 以 280A 电流充电至企业规定最大截止电压的 1.5 倍或充电 1h 后停止。</p>
2	过放电 Over-discharge Test	不爆炸、不起火、不漏液 No explosion. No fire. No leakage.	<p>a) Standard charge 电池标准充电;</p> <p>b) 以 280A 电流放电 90min 或电压降为 0V。 Discharged for 90min with 280A current or voltage becomes 0V.</p>
3	短路 Short-circuit Test	不爆炸、不起火 No explosion. No fire.	<p>a) Standard charge 电池标准充电;</p> <p>b) Connect the battery positive and negative terminals with wire for 10min directly. The resistance of external line should be less than</p>

			5mΩ. 将电池正、负极经外部短路 10min, 外部线路电阻应小于 5mΩ。
4	挤压 Crushing Test	不爆炸、不起火 No explosion. No fire.	a) Standard charge 电池标准充电; b) 按下列条件进行试验: According to the following test conditions: — 挤压方向: 垂直于蓄电池极板方向施压。 Crushing direction: Pressure perpendicular to the battery plates. — 挤压程度: 直至电芯电压达到 0V 或变形量达到 30% 或挤压力达到 13±0.78KN。 Squeeze level: Until the cell voltage reaches 0V or the deformation reaches 30% or the extrusion force reaches 13±0.78KN
5	跌落 Drop Test	不爆炸、不起火 No explosion. No fire.	a) Standard charge 电池标准充电; b) The positive or negative terminal of the single cell is freely dropped from a height of 1.5m to the concrete floor once. 单体电芯的正极或负极端子朝下从 1.5m 高度处自由跌落到水泥地面上 1 次。
6	低气压 Low air pressure	不爆炸、不起火、不漏液 No explosion. No fire. No leakage.	a) Standard charge 电池标准充电; b) The single cell places in a low pressure 11.6KPa environment for 6h. 单体电芯在低气压 11.6Kpa 环境中静置 6h
7	加热 Heating	不爆炸、不起火 No explosion. No fire.	a) Standard charge 电池标准充电; b) 单体电芯以 5°C/min 的速率由环境温度升至 130±2°C 并保持 30min。 The single cell rises from ambient temperature to 130±2°C at a rate of 5°C/min and keeps it for 30min.
8	热失控 Thermal runaway	不爆炸、不起火 No explosion. No fire.	a) Standard charge 电池标准充电; b) 触发电芯达到热失控 Trigger Single cells to achieve thermal runaway.
<p>注: 电池安全试验参考 GBT 36276-2018 《电力储能用锂离子电池》。</p> <p>Notes: Refer to GBT 36276-2018 <i>Lithium ion battery for electrical energy storage</i></p>			

## 5.8 Storage Performance 储存性能

NO. 序号	Parameter 参数	Specifications 产品规格	Condition 条件
-----------	-----------------	------------------------	-----------------

1	Recovery capacity (Short term) 可恢复容量 (短期)	$\geq 97\%$	Standard charged to 30% SOC, and storage for 30 days at $25 \pm 2^\circ\text{C}$ 标准充电到30%SOC, $25 \pm 2^\circ\text{C}$ 温度储存30天
2	Recovery capacity (Long term) 可恢复容量 (长期)	$\geq 95\%$	Standard charged to 30% SOC, and storage for 180 days at $25 \pm 2^\circ\text{C}$ 标准充电到30%SOC, $25 \pm 2^\circ\text{C}$ 温度储存180天

## 6. Precautions for Transportation 运输注意事项

The Cell shall be shipped in capacity range of 30% ~ 40% or in accordance with customers' requirement. The remaining capacity before charging shall be changed depending on the storage time and conditions.

单体电池按 30%~40%的充电容量或客户要求出货,电池出货后充电前的剩余容量取决于储存时间和条件.

The batteries should be packed in boxes for transportation which should be conducted not less than 30% SOC. They are also should be prevented from vibration, shock, extrusion, sun-scorched and rain-drenched. It could be delivered by car, train, boat, etc. If it will be delivered by air, please refer to MH/T 1020-2013 Standards for transport of lithium batteries by air.

电池应在 $\geq 30\%$ 荷电状态下包装成箱进行运输,在运输过程中应防止剧烈振动、冲击或挤压、防止日晒雨淋,不得倒置。适用于汽车、火车、轮船等交通工具运输。航空运输请参照 MH/T 1020-2013《锂电池航空运输规范》。

## 7. Warranty 质量保证

The Warranty period of cell is made according to business contract. However, even though the problem occurs within this period, AESC won't replace a new cell for free as long as the problem is not due to the failure of AESC manufacturing process or is due to customer's abuse or misuse.

自出货之日起,电池的保质期限依合同而定.但是,在此期限内,如果非 AESC 的制程原因。而是客户的误用造成的电池质量问题,AESC 不承诺免费更换.

AESC will not be responsible for trouble occurred by handling outside of the precautions in instructions.

AESC 对违反安全守则操作所产生的问题不承担任何责任.

AESC will not be responsible for trouble occurred by matching electric circuit, cell pack and charger.

AESC 对与电路,电池组,充电器搭配使用所产生的问题不承担任何责任.

AESC will be exempt from warrantee any defect cells during assembling after acceptance.

出货后客户在电池组装过程中产生的不良电池不在 AESC 质量保证的范围之列.

## 8. Storage and Shipment Requirement 存储及运输要求

Item项目	Requirement要求	
储存 Storage environment	Short period less than 1 month 短期少于1个月	-30°C ~ +55°C, 95%RH Max
	Long period more than 3 months 长期超过3个月	-10°C ~ + 45°C, 90%RH Max
	Recommend storage 推荐存储	-10°C ~ + 25°C, 85%RH Max

长时间存储：如果电芯长时间存储，电芯 SOC 状态不应低于 5%。且每 6 个月进行一次充放电。  
Long time storage : If the cell is stored for a long time, the cell's storage capacity rate should be less than 60% .  
Also, it is recommended to charge the cell every six months.

## 9. Warning and Cautions in Handling the Lithium-ion Cell 电池使用时警告事项及注意事项

Lithium-Ion rechargeable batteries subject to abusive conditions can cause damage to the cell and/or personal injury. Please read and observe the standard cell precautions below before using utilization.

滥用锂离子充电电池可能会造成电池的损害或人身的伤害.在使用锂离子充电电池以前,请仔细阅读以下的安全守则:

Note 1. The customer is required to contact AESC in advance, if and when the customer needs other applications or operating conditions than those described in this document.

注释 1. 如果客户需要其它应用程序或本文档中描述之外的操作条件，客户需要提前联系 AESC。

Note 2. AESC will take no responsibility for any accident when the cell is used under other conditions than those described in this Document.

注释 2.在该文件说明的条件之外使用该电池而产生的事故，AESC 不承担任何责任。

### Warning! 警告

Danger warning (it should be described in manual or instruction for users, indicated especially) to prevent the possibility of the battery from leaking, heating, explosion. Please observe the following precautions:

**危险警告：**（应在使用说明手册或说明书中，特别注明）为防止电池可能发生泄漏，发热，爆炸，请注意以下预防措施：

Don't immerse the battery in water and seawater. Please put it in cool and dry environment if no using.

严禁将电池浸入海水或水中，保存不用时，应放置在阴凉干燥的环境中。

Don't use and leave the cell near a heat source such as fire or heater.

禁止将电池在热高温源旁，如火，加热器等旁边使用和留置。

Do not use or leave the cell under the blazing sun (or in heated car by sunshine).

不要将电池放置在太阳光直射的地方。

Being charged, using the battery charger specifically for that purpose.

充电时请选用锂离子电池专用充电器。

Don't reverse the positive and negative terminals

严禁颠倒正负极后使用电池。

Do not disassemble or modify the cell.

不要拆卸或修整电池。

Do not use the cell with conspicuous damage or deformation..

不要使电池受到明显的损害或变形。

Don't connect the cell to an electrical outlet directly.

严禁将电池直接插入电源插座。

Don't discard the cell in fire or heater.

禁止将电池丢入火或加热器中。

Do not short circuit, over-charge or over-discharge the cell.

不要将电池短路,过充或过放。

Don't transport and store the cell together with metal objects such as necklaces, hairpins.

禁止将电池与金属,如发卡、项链等一起运输或存储。

Do not use lithium ion battery and others different lithium battery model in mixture.

禁止与液态锂离子或不同型号的锂电池混合使用。

Keep the battery away from babies.

电池应远离小孩。

Don't strike, throw or trample the cell.

禁止敲击,抛掷或踩踏电芯等。

Prohibition of use of damaged cells.

禁止使用已损坏的电池。

Battery pack designing and packing Prohibition injury batteries.

电池外壳设计和包装禁止损伤电池。

The battery replacement shall be done only by either cells supplier or device supplier and never be done by the user.

更换电池应由电池供应商或设备供应商完成,用户不得自行更换。

Be aware discharged batteries may cause fire; tape the terminals to insulate them..

废弃之电池应用绝缘纸包住电极，以防起火，爆炸。

Do not use it in a location where is electrostatic and magnetic greatly, otherwise, the safety devices may be damaged, causing hidden trouble of safety.

禁止在强静电和强磁场的地方使用，否则易破坏电池安全保护装置，带来不安全的隐患。

Do not directly solder the battery and pierce the battery with a nail or other sharp object.

禁止直接焊接电池和用钉子或其它利器刺穿电池。

When disposing of secondary cells, keep cells of different electrochemical systems separate from each other.

二次电池处理时，请将电池和其他电化学体系的产品分开。

### **Cautions! 小心**

Don't use or leave the cell at very high temperature conditions (for example, strong direct sunlight or a vehicle in extremely hot conditions).

禁止在高温下（直热的阳光下或很热的汽车中）使用或放置电池，否则可能会引起电池过热，起火或功能失效，寿命减短。

## **10. Emergency Treatment 紧急情况处理**

If the cell leaks and the electrolyte get into your eyes, don't wipe eyes, instead, thoroughly rinse the eyes with clean running water for at least 15 minutes, and immediately seek medical attention. Otherwise, eyes injury can result.

如果电池发生泄露，电解液进入眼睛，请不要搓揉，应用清水冲洗眼睛，必要时请立即前往医院接受治疗，否则会伤害眼睛。

If the cell gives off an odor, generates heat, becomes discolored or deformed, or in any way appear abnormal during usage, recharging or storage, immediately remove it from the device or cell charger and stop using it.

如果电池发出异味，发热，变色，变形或使用、存储、充电过程中出现任何异常现象，立即将电池从装置或充电器中移开并停用。

In case the cell terminals get dirty, clean the terminals with a dry cloth before use.

如果电池弄脏，使用前应用干布抹净。

## **11. The Restriction of the Use of Hazardous Substances 有害物质控制要求**

This model of lithium-ion cell is in accordance with our company's request of "The hazardous substances and material management standard" or customer's requirements.

本型号锂离子电池符合本公司《有害物质与材料管理规范》要求或参照客户要求执行！